



Seattle Pacific University
LIBRARY
Discover, Create, Share

Seattle Pacific University
Digital Commons @ SPU

Honors Projects

University Scholars

Spring June 8th, 2018

Wind Turbine Design: Analysis and Experimentation of Electro-Magnetic Alternator Design

Mark Hans Ewald Steinke
SPU

Follow this and additional works at: <http://digitalcommons.spu.edu/honorsprojects>

 Part of the [Electromagnetics and Photonics Commons](#), and the [Power and Energy Commons](#)

Recommended Citation

Steinke, Mark Hans Ewald, "Wind Turbine Design: Analysis and Experimentation of Electro-Magnetic Alternator Design" (2018).
Honors Projects. 74.
<http://digitalcommons.spu.edu/honorsprojects/74>

This Honors Project is brought to you for free and open access by the University Scholars at Digital Commons @ SPU. It has been accepted for inclusion in Honors Projects by an authorized administrator of Digital Commons @ SPU.

Wind Turbine Design: Analysis and Experimentation of Electro-Magnetic Alternator Design

by

MARK HANS EWALD STEINKE

FIRST READER, JOHN LINDBERG

SECOND READER, KEVIN BOLDING

A project submitted in partial fulfillment
of the requirements of the University Scholars Honors Program

Seattle Pacific University

2018

Approved _____

Date 6/8/18

Wind Turbine Design: Analysis and Experimentation of Electro-Magnetic Alternator Design (June 2018)

Primary A. Mark Hans Ewald Steinke, First Reader Dr. John Lindberg, Second Reader Dr. Kevin Bolding

Abstract— This article explores the alternator designs for small scale wind turbines and the aspects that affect the performance of these alternators. It explores the design and testing process used to quantify, visualize, and understand the relationship between the wind turbine stator design and the performance. Additionally, the paper analyzes the data collection method using a test jig powered by a hydraulic motor set up by previous groups of students and the data intended to be collected using actual field tests on Whidbey Island located at Camp Casey. These tests were intended to identify favorable combinations of alternators and blades. However, due to a lack of wind, only a small amount of data was collected. In addition to this test, it also discusses another experimental test designed to analyze the importance of minimizing the spacing between the magnetic rotors and the stators in maximizing the performance of the alternator.

I. WIND TURBINE DESIGNS

HERE are two different styles of wind turbines that are commonly used: vertical-axis and horizontal-axis turbines. Vertical-axis turbines are oriented such that the wind direction does not matter and it is only dependent on the wind power coming in. Additionally, it is designed with the generator located on the ground at the bottom of the rotating shaft. Because of this, the tower does not need to support the weight of the generator itself so it can be a much larger generator, and therefore can be more efficient in harnessing the power. This also results in it being easier to maintain and repair the generator. Although it is convenient in these regards, the design comes with two large downfalls. Due to the vertical design, the blades are located closer to the ground, resulting in less wind power from the drag of the earth. As you can see in Figure 1, the wind power density increases exponentially in relation to the height

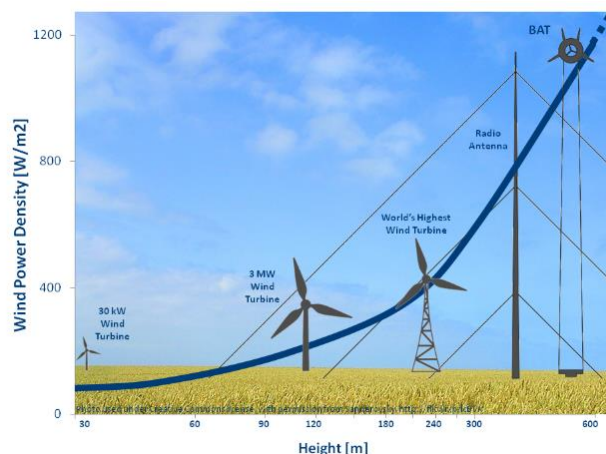

Fig. 1. Wind power density in relation to the vertical height from the ground, showing the importance of having turbines located at a high altitude to reduce drag generated by the surface of the earth. This graph was used from the following article <http://euanmearns.com/high-altitude-wind-power-reviewed/>

Horizontal-axis turbines, on the other hand, are designed such that the generator is located at the top of the tower where the blades meet up with the tower. Because of this, the generator is designed to be smaller because the weight needs to be fully supported by the tower. Additionally, the horizontal axis wind turbine needs to be oriented into the direction of the wind to optimize the power output, which is often done either through the means of a tail vane. Larger turbines commonly use a more complex motor to control the orientation of the blades in relation to the wind. Additionally, with horizontal axis wind-turbines it is easy to decrease the power output simply by adjusting the pitch of the blades. This can be useful when the wind is stronger than expected to prevent the turbine from being damaged. The horizontal axis turbine is more commonly used and is also the style that was used to conduct the experiments later in this paper.

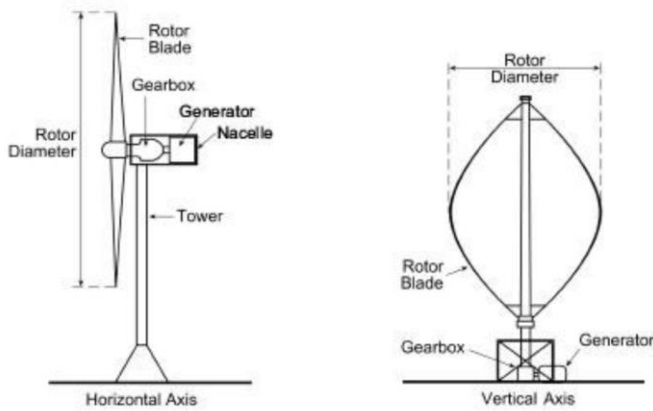

Fig. 2. The two different styles of wind turbines, both horizontal and vertical axis. Includes labels of the various components of each style. This image was taken from the Scottish article on renewable energy from <https://www.researchgate.net/figure/The-diagram-shows-horizontal-and-vertical-axis-wind-turbine-design-Scottish-government>

II. ALTERNATOR DESIGN

The alternator that we built for the project was based off a design in *Homebrew Wind Power* by Fink Bartman. The design consists of three main components; the alternator mount, two rotors, and the stator. The alternator mount is the mechanical component that holds the rest of the alternator together and can be mounted on top of the wind tower when the system is completely put together.

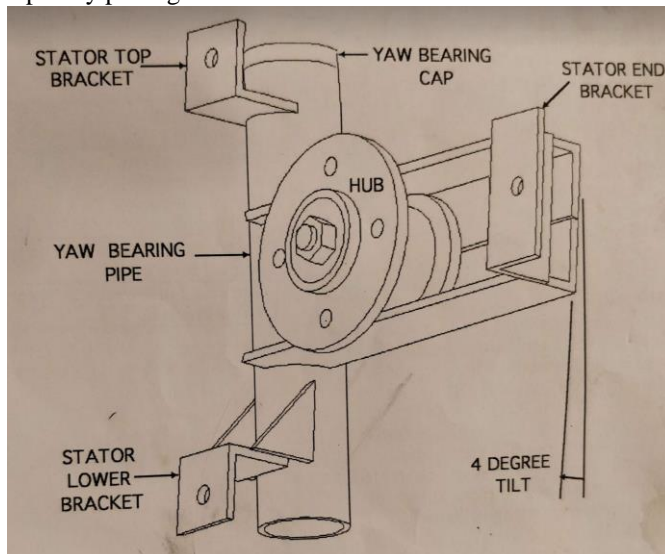

Fig. 3. Diagram of the alternator mount including the key components. This image was taken from the Hugh Piggot *How to build a wind turbine*.

The rotating parts of the alternator are referred to as the rotors. Each alternator consisted of two individual rotors which would be aligned across from the other. The individual rotor consisted of 12 magnet blocks aligned around the rotor alternating in the polarity towards the face of the stator from north to south and so on. It was important that each of these magnet blocks be equidistant from each other to maintain balance while the rotor spins and to maintain a consistent output voltage. To do this, we used a mold to ensure that we located

the magnets in the correct location and had to exercise caution to prevent the magnets from adhering to one another while placing them into the mold. The magnets were then solidified into the mold using polyester based resin material. Four holes were drilled into each magnet plate for the magnets to be attached onto the alternator.

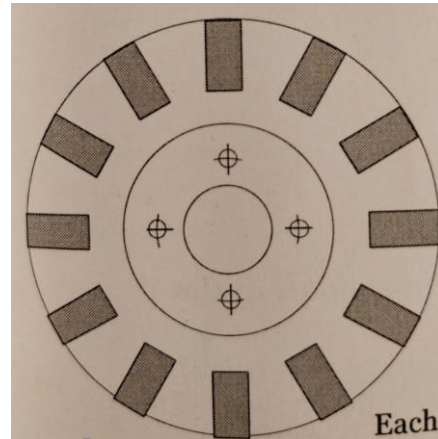

Fig. 4. Diagram of the layout for the magnet blocks on the steel plate. Image taken from Hugh Piggott's *How to build a wind turbine*

The stationary part of the alternator, also known as the stator, was the aspect of the alternator that we had the most control over the design. The Stator consisted of 9 coils of magnet wire wound numerous times. As a general understanding from *Homebrew Wind Power*, a 12 Volt battery would be best charged by 14AWG wire wound 70 times, and a 24 Volt battery would be better charged by 17AWG wire wound 140 times. We intended to make two of each style of these stators to compare their performances in different scenarios. When laying out the coils, we had to make sure that each of the coils was laid down on the circle with the coils going in a counter clockwise direction. The ends of the coils were then sanded down and every third coil was connected as shown in Figure 5 and with points A, B, and C all being connected as well. This left three points on the stator for which to connect to the rectifier circuit.

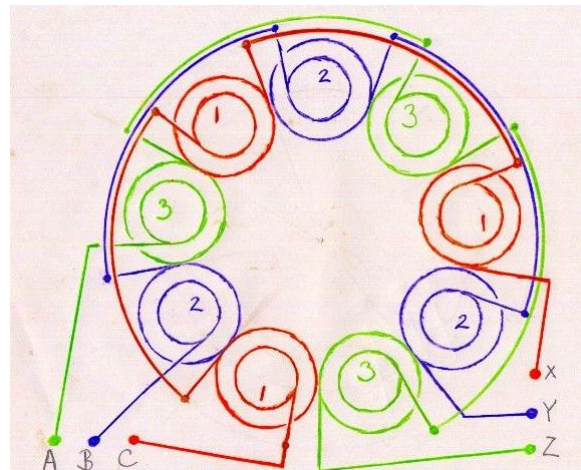

Fig. 5. The wiring diagram for the 9-coil stator build and wired in the star pattern. Operational for three phase power. A,B, and C are all connected together and X, Y, and Z are the three outputs from the system. This diagram was taken from <https://www.otherpower.com/stator.html>

The rectifier circuit then converts the AC power to DC power.

The alternators will generate power from the changing magnetic field passing over the coils as the magnets are propelled by the torque from the blades. This changing magnetic field will cause a change in the magnetic flux across the coils, which then generates a circular electric field through the individual coils, and this field will generate a difference in electrical potential energy proportional to the number of turns in each coil. The changing electrical field will result in an alternating electrical potential energy that can be measured at the three output wires, and when an electrical load is connected to these points, the electrical potential will cause electrons to move across the load resulting in current. The power generated by the alternator (Watts) is equal to the product of the electrical potential energy (Volts) and the current through the load (Amps).

III. CAMP CASEY TESTING PROCESS

For the purpose of testing the turbines, we used the horizontal axis turbines that were designed based off the book *Homebrew Wind Power* and were built to be placed on top of a 30 foot tower.



Fig. 6. Setting up the wind turbine at Camp Casey

We tested four different sets of blades and two different alternator designs. The four sets of blades that were tested included a heavier wooden blade set, a lighter wooden blade set, one set of blades that included a sinusoidal curvature pattern on the edge of the blades to help reduce the drag, and one set that was built using PVCs. Each of these blades were expected to operate differently under different wind conditions. The two different alternator designs that were to be used with these different blade sets were one style built with 14AWG (gauge) magnet-wire wound 70 times per coil (Stators 1A and 1B), and one style built with 17AWG magnet-wire wound 140 times per coil (Stators 2A and 2B). By using different combinations of the blades and alternators we hoped to be able to collect significant data to determine which blade/alternator combinations perform best at which wind speeds.

To do this, we needed to continuously measure both the wind speed and power generated by the turbine while adjusting the load resistance. To measure the wind speed, we used an

anemometer at the top of one of the two towers communicating with the computer. To simultaneously measure the power alongside the windspeed we measured the output voltage from the turbine and knowing the load resistance, calculated the power. This would allow data to be collected from two turbine designs simultaneously. Figure 7 below shows the order in which each stator/ blade set would be tested on the two different towers.

Test #	Tower 1		Tower 2	
	Stator Set	Blade	Stator Set	Blade
1	1A	PVC	1B	Small Wood
2	2A	Large Wood	2B	Whale Blade
3	1B	PVC	1A	Small Wood
4	2B	Large Wood	2A	Whale Blade
5	1A	Whale Blade	1B	Large Wood
6	2A	PVC	2B	Small Wood

Fig. 7. Camp Casey test plan table showing the stator/ blade combinations that were to be tested simultaneously on the towers

By testing the alternators and blade combinations in this order, from the first four tests, we would be able to determine whether each of the similar stator sets had the same electrical characteristics, and then through the last two tests, we would be able to complete the tests to identify how each of the four blade performs with both alternator designs. If the tests went as expected, the data collected should from test one should match the data collected on that tower in test three and the same for tests two and four.

When testing the various turbines by measuring the output current and voltage, the primary factor that we could control was the load resistance. To do this, we had a load cell with seven resistive loads in parallel that could be toggled on and off. The resistive values included the following; 150, 75, 40, 15.6, 7.5, 4, and 2. These values were arranged in such that each coincided with a binary digit and could be toggled on and off. Because they were in parallel, the equivalent resistance could be calculated as follows: $\frac{1}{R_T} = \frac{1}{R_1} + \frac{1}{R_2} + \frac{1}{R_3} + \dots$ where R_T is the equivalent resistance of the load cell. By performing a binary search pattern with the switches and measuring the output power, we could determine the optimal load resistance for each test. Since some of the resistive loads were as low as two ohms, occasionally a large amount of power would flow through the switches. This would cause cheaper switches to occasionally have an electrical short and break so it was important to use heavy duty switches rated to a current of 30 amps. The load switch box can be seen below in Figure 8.

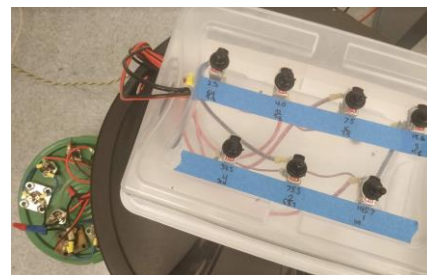

Fig. 8. Switch box for the load cell including all the individual measured resistances for each switch

IV. TESTING RESULTS

Testing at Camp Casey on Whidbey Island was planned to take place on April 28th, 2018. We encountered multiple issues during the weekend of testing. Primarily there was too little wind to get the blades to spin, hence we were only able to gather a limited amount of data. Additionally, we came to realize that the magnets on one of the sets of magnet plates were misaligned. Also, we determined that stators 2A and 2B did not match. This is because one the sets was designed by a previous group of students and while we assumed that it was designed using 17AWG wire wrapped 140 times, it was designed using 18AWG wire wrapped 160 times. Finally, the rotational component on one of the generator sets did not rotate smoothly on its own due to excess internal friction.

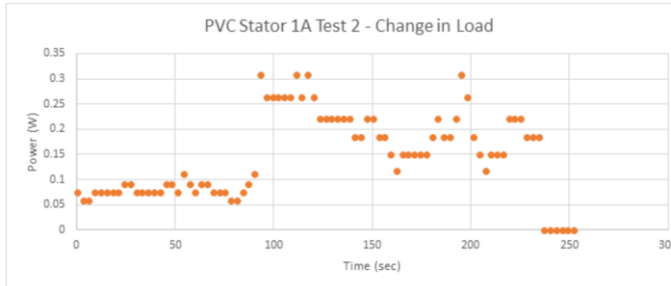

Fig. 9. Shows the collected data from Camp Casey testing stator 1A with the PVC blades in a low wind environment

Although many things went wrong with the planned testing We collected a small data set as seen in Figure 9. The table shows the power output over time in a low wind environment. Where the power jumps up at 100 seconds is where the load resistance was changed. After that, the changes in wind speed can be seen through the changes in output power and at 230 seconds into the trial, the wind speed dropped too low to generate any power. With changing the load resistance, still the power peaked at just over 0.3 Watts. Although the data collected in the field was very limited, we were still able to gather a significant amount of data on the alternators using a test jig built by a previous group of students.

V. TEST JIG TESTING METHODS

Before going to Camp Casey to test the stators, we performed a series of tests on a test jig located in Otto Miller Hall. The test jig consists of a hydraulic motor connected to a sprocket gear that rotates a bicycle chain, which will be connected to another sprocket gear connected to the turbine. The hydraulic motor and turbine have locations on the wall on which they can be mounted to transfer the mechanical power from the motor to the turbine. A hydraulic motor was chosen for the testing because unlike dc electric motors, a hydraulic motor will provide power at a given torque rather than a given rotational velocity. Because of this, the motor can simulate the torque generated by the turbine blades. Figures 10 and 11 show how the test jig should be set up.

When testing the different generator designs, the two factors that we were able to adjust were the load resistance and the power level of the hydraulic motor. We ran a test on each

alternator set at three different power settings on the hydraulic motor; 2, 3, 5. The process of the test is as follows and requires two people to conduct efficiently. Begin mounting the alternator on the test jig with the sprocket attached and connecting the chain so it matches image 10.

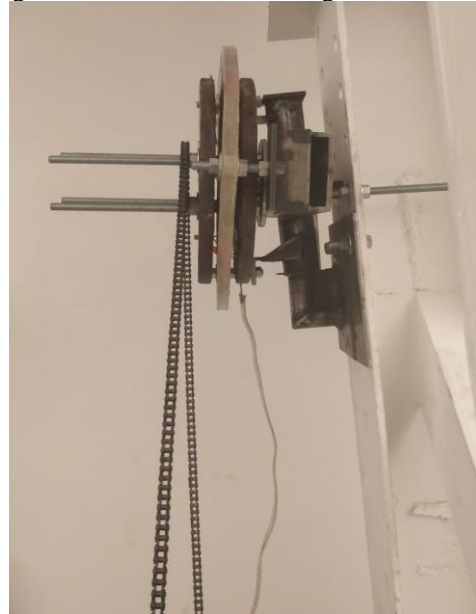

Fig. 10. Side view of the test jig set up with the alternator and chain completely assembled ready to be tested

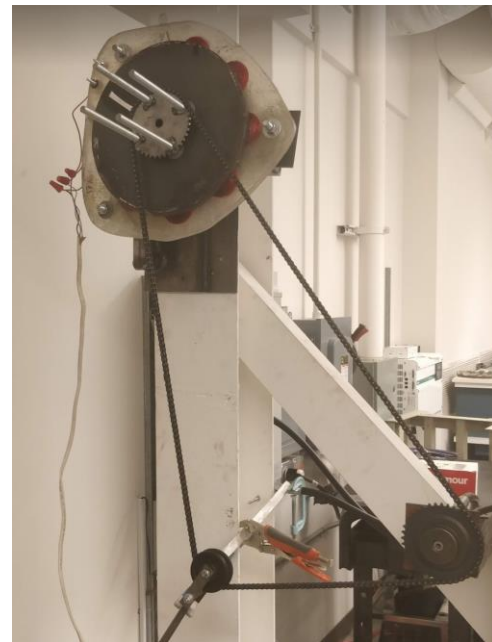

Fig. 11. Front view of the test jig set up in Otto Miller Hall

Next, pull on the chain to ensure the chain and sprockets are aligned in such a way that the chain will not jump off the track. If needed, adjust the location of the sprocket on the turbine to fix the alignment. In a few of the tests, this was not done correctly resulting in the chain slipping forcing us to immediately power off the jig. Once this is set up, connect a Fluke power meter to measure the voltage across the two poles of the output and a current sensor to measure the current through one of the two wires leading into the load cell. At this point data was ready to be collected. Beginning with the load set to 150

ohms and the test jig turned on, we measured the current, voltage, and RPM's (rotations per minute) of the rotors. By multiplying the current and voltage, the current could be calculated. By systematically toggling the various switches on/off we could narrow down and isolate the optimal load resistance to get the highest output power.

VI. TEST JIG RESULTS

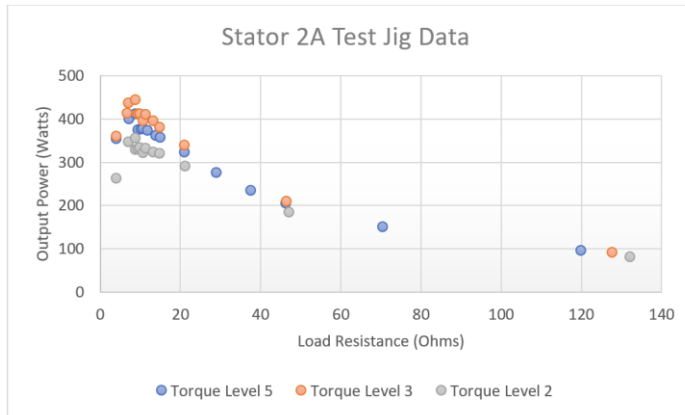

Fig. 12. Comparison between the Load Resistance and the Output Power of the alternator that was designed using 18AWG wire wound 160 times per coil. This also shows the comparison between the different torque power levels of the stator

As can be seen in Figure 12, although we expected to see a correlation between the torque level and output power, the change in Torque Level did not seem to have as significant an impact as expected. In fact, it appears Torque Level 3 provided the greatest output power of the three, although it was only by a small amount. This same correlation between the data points and the Torque Level can be seen in the data collected by the other alternator sets as well. For this reason, when discussing the differences between the various alternator the data used will be taken from the Torque Level 3 measurements.

To identify the differences between the stator sets, we will begin by comparing the Resistance to Power graphs of each of the three stators that we conducted the measurements on. Although it was the original intention to gather data on all four of the stators that were to be brought to Camp Casey, not all the data was able to be collected due to the way that one of the stators that were to be brought to Camp Casey, not all the data was able to be collected due to the way that one of the magnet plates was designed. Unlike the other three plates, one of them was made with a fiber glass backing which meant that the magnetic field from the magnets was present on both sides of the plate. When set up on the test jig, the magnetic force applied by this field affected the chain in such a way that we were unable to run the machine without the chain detaching from the gear. In addition to this problem with the magnet plates, it was also discovered that using fiberglass as the back of the magnet plate rather than steel also caused the magnetic field on the side of the stator to be weaker. This was initially hypothesized after having to remove many individual washers and nuts from the individual magnets on both sets of plates. After more consideration, it is understood that in theory the steel backing should act to enhance the magnetic field strength by a significant factor. A weaker magnetic field would result in the alternator producing less power at a given rotational velocity, and hence the data collected from the set with the fiber

glass magnet plates would be less than desired. More details on the effect of a changing magnetic field can be found in section VII.

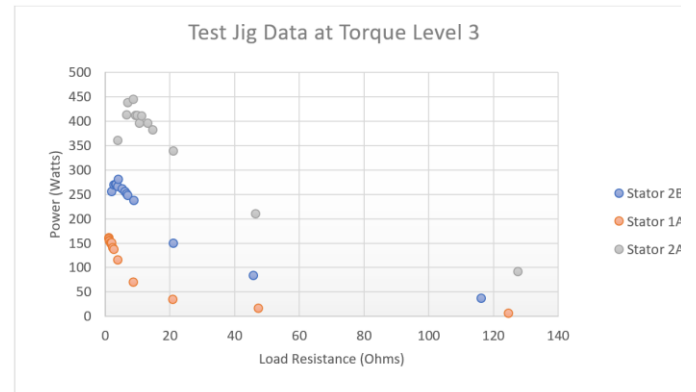

Fig. 13. Comparing three of the various alternator sets on the test jig. Stator 2B made of 18AWG wire wrapped 160 times, Stator 1A made of 14AWG wire wrapped 70 times, and Stator 2A made of 17AWG wire wrapped 140 times.

After collecting the data shown in figure 13, it is clear that stator 2A performed best of the three in all of the tests. This is likely due to the number of rotations for each coil in the stator. The corresponding turns to power ratio appear to directly relate to the output power as the highest performing stator had 160 turns, followed by stator 2B with 140 turns, and Stator 1A with the least power and having only 70 turns per coil. Although this seems to show that Stator 2A is clearly the most effective, there are a few variables in this test that are skewing the data in favor of Stator 2A. The most significant variable is that the alternator is being tested at a much greater power output than would be expected in actual field test scenarios. This data shows that the peak output power measured at a given instant was almost 450 Watts. The hydraulic motor used with the test jig is rated to output one HP (Horsepower) of torque which is the equivalent to 746 Watts of power. We also expect that there will be a considerable amount of power loss in the system due to friction between the chain and the sprockets and due to the electrical inductance through the magnetic coils as well. This is the total power we would expect be able to get out of the system. If the Torque Level adjustment lever was working as expected, we would be limited to only 0.3 times that power which is 228 Watts. The stators designed with more coils are made to be more effective in these high wind scenarios, and it is for this reason that they performed significantly better using the test jig.

The other factor that was important in analyzing the performance of each of the stator sets is the relationship between the voltage and the rotational velocity of the rotors. Theoretically, there should be a direct correlation between the rotational velocity and the voltage, which is dependent on the strength of the magnetic field and the number of turns per coil. Figures 14 and 15 show the relationships between the voltage, resistance and the rotational velocity of the rotors between each of the three stators used for the test.

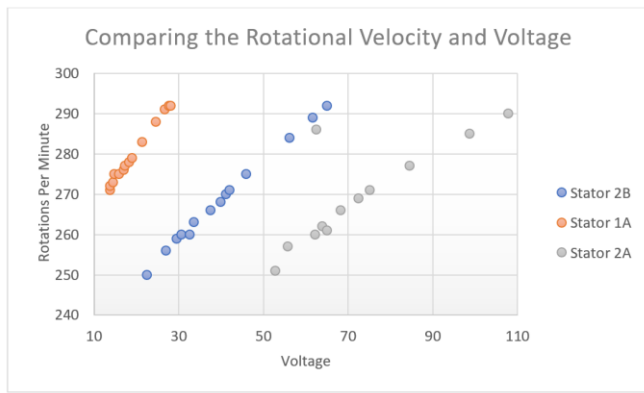

Fig. 14. The relationship between the rotational velocity and the voltage when each of the alternator sets were run on the test jig at a torque level of 3.

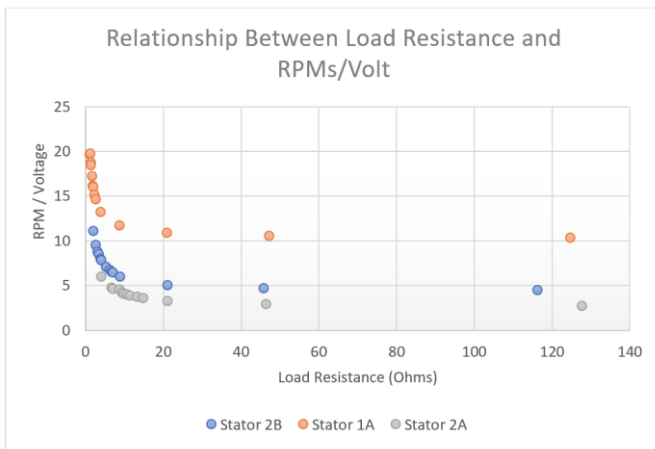

Fig. 15. The relationship between the Load Resistance and the ratio of the rotational velocity to voltage.

From the data collected and represented in the figures above, the relationship between the number of turns per coil in the stator and the RPM/Volt ratio becomes very clear and backs up the theoretical expectation. In figure 14, at any given Load Resistance, the ratio of the RPM’s per volt for stator 1A is approximately double that of Stator 2B and Stator 2A. This means that for stator 1A, it takes approximately twice the rotational velocity to generate the equivalent voltage. This also aligns with the fact that stator 2B has twice as many turns per coil, and hence generates twice the voltage. This also means that stator 2B will require more torque and less speed to generate the equivalent voltage as that from stator 1A.

It is also interesting to note the apparent curve in the data that appears between zero and 10 ohms in figure 14. This is largely due to the internal resistance and inductance of the wires inside the stator. When disconnected, the resistance measured between two of the poles within stator 1A measured to be 0.9 Ohms, and 2.7 Ohms for stator 2B. Therefore, as the load resistance decreased to a value close to these numbers, a larger proportion of the total output power was through the coils rather than the resistive load. Because of this, the alternators are less efficient at low resistance loads.

VII. ROTOR GAP WIDTH TESTING

In addition to exploring the differences in characteristics between the different sets of alternators that were tested, it was also important to observe how a change in the distance between the magnet plates and the stator affected the alternator’s power output. Previously, when building the alternators, it was generally understood that it was important for each of the magnet plates to be as close as physically possible to the stator without touching in order to maximize the effectiveness of the alternator. The exact benefit of this, however, was not known precisely. To test this, we began with one of the alternator sets built with as small a gap as possible and, after measuring the distance between the two magnet plates with a caliper, gathered data with it on the test jig over a few set load resistances. We then removed the alternator from the test jig and raised both the top magnet plate and stator set slightly and repeated the test. We did this one more time, raising the top magnet plate to the highest position we could while still being able to run the tests safely on the test jig. The results of these tests can be seen in the graph below.

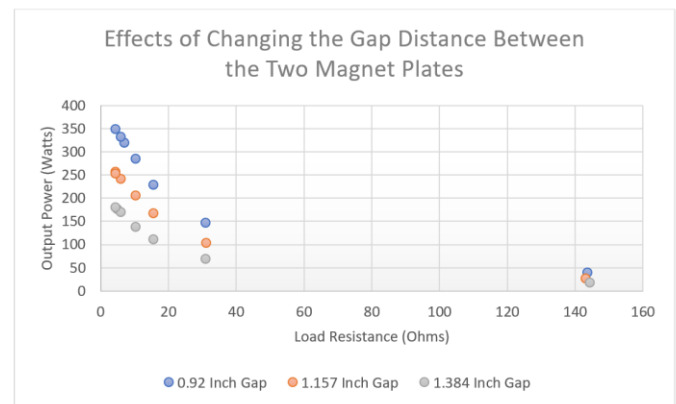

Fig. 16. Compares the power and load resistance of the exact same alternator set, adjusting nothing but the distance between the two magnet plates. Adjusting the gap between the plates results in a change in magnetic field strength at the location of the stator, and hence a change in the alternators power output.

From the data shown it is clear that the larger gap resulted in less power generated at every load resistance. This shows that the power and gap size are inversely proportional to some degree. However, after looking at the data table itself, it appears the power is not proportional to $1/D$ but rather is proportional to $1/D^2$. Magnetic field strength is also proportional to $1/D^2$ and hence it makes sense that the power output is proportional to the same quality. From this we are able to deduce that, with the test jig, the power output is directly proportional to the strength of the magnetic field. Based on this knowledge and the confirmation that the distance between the two plates is a significant factor, it would be worthwhile to consider the possibility of making the coils slightly larger in diameter and thinner in width to decrease the width of the stator and maximize the magnetic field.

VIII. APPENDIXES

AUTHOR’S REFLECTION

Living on a world that we were put on by a gracious, caring God, we were made to be caretakers of the land in which we

are living. Because of this, we have a responsibility to the earth we are living on and should seek to preserve it to the best of our ability. Right now in the US, a large portion of our power is coming from non-renewable resources such as coal and fossil fuels. In order to decrease the power being supplied by these resources, we need to either seek to decrease power consumption or find other means of power production. Wind power is a great source of alternative energy and it is for this reason that I chose to seek how to optimize power output through wind turbine design. By seeking to understand the world that God created, we can also learn more about the God the created the world through the understanding of physics.

Additionally, I believe God has gifted us with creative minds, and it is our duty to use them to do work that would be pleasing to him. Although this project may not have a direct significant impact on the energy sector, it will make room for more growth and understanding of future students at SPU when they seek to learn more about alternative energy sources. This project will enable them to grow in their understanding that can be used to further develop the way we approach learning about wind turbines. This project has been an exercise of the creative mind God created me with.

ACKNOWLEDGMENT

I want to thank John Lindberg and Kevin Bolding for their assistance on my honors projects, as well as all the students who were a part of the independent study for small scale wind power and for all the hard work they put in to get the turbines set up for testing in the field at Camp Casey. I would also like to thank all my friends and family for the constant support throughout my undergraduate education.

REFERENCES

- [1] Bartmann, D., Fink, D. and Sagrillo, M. (2009). *Homebrew wind power*. Masonville, CO: Buckville.
- [2] Piggott, H. (2005). *How to build a wind turbine*. [Dundonnell, Ross shire, Scotland]: H. Piggott-Scoraig Wind Electric.